

# E11 HEAVY DUTY XTREME Primary Cleaner



GET THE **EAGLE EDGE!**  
MADE IN THE U.S.A.



**Blade  
Height  
11"**

**Main Body is  
3" sq. tubing**

**2<sup>3</sup>/<sub>8</sub> Schedule 80 Mounting Tube  
Powder Coated**

**Cleaners 24-84" Belt Width  
Standard Blades -6, -12 & -18 Belt Width**

**AVAILABLE IN ALL STAINLESS STEEL**

## **UNIVERSAL MOUNTING BRACKET**

- † Can be flange mounted or foot mounted
- † Composite molded bushing eliminates corrosion and build-up between bracket and mounting tube. Allow constant blade pressure to belt.
- † Elongated holes allow for easy alignment of installation.
- † Set screw that allows pre-tensioning of cleaner making it more accurate.

***"Not just assembled in the U.S.A.  
but made in the U.S.A."***

## **EZ TORSION SYSTEM**

### **LIFETIME WARRANTY**

This revolutionary design is the simplest and most accurate tensioning system on the market.

Only 4 components make up the EZ Torsion System.

- † Universal Torsion Mounting Bracket
- † Stainless Steel Spring
- † EZ Torsion Ring
- † Tension Guide Cap

**EASY TO SET AND  
STAYS SET**

**Patent Pending**

## **Ev-r-wear™ Blade**

Our special formulated urethane with additives has been tested and proven to last longer than any other blade on the market.

### **WE GUARANTEE IT . . .**

- † Premium urethane
  - † Additive for lubricity (non-stick)
  - † Additive for high abrasion
- "With over 35 years molding experience."**

**AMERICAN EAGLE MANUFACTURING LLC**

[www.AmericanEagleManufacturing.com](http://www.AmericanEagleManufacturing.com)

1-866-713-8985

# BY FAR THE EASIEST CLEANER TO INSTALL AND MAINTAIN

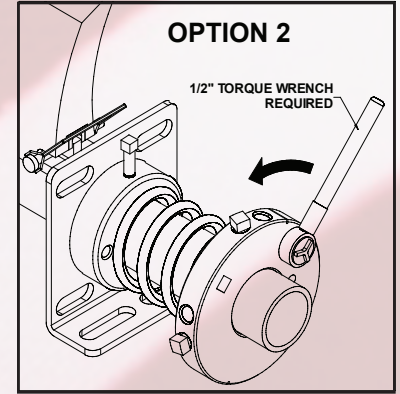
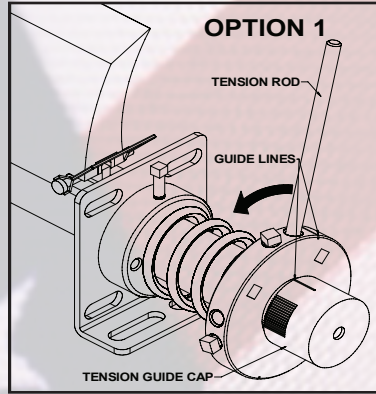
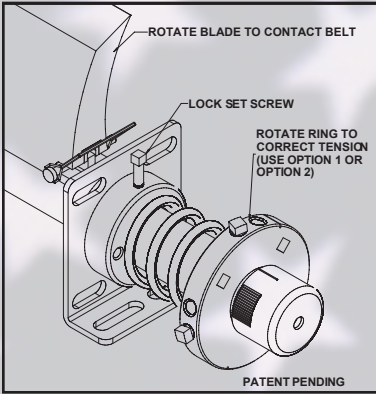

Once the correct tension is set, tighten the 2 set screws on the Easy Torsion Ring then release the set screw on top of the Universal Torsion Mounting Bracket, to transfer the tension to the blade.

## E11HDX CLEANER

BELT WIDTH MINUS 6" BLADE  
ORDERING INFORMATION E11HDX Series

BELT WIDTH	BLADE WIDTH	S.S. SPRING	ORDER NO.	MOUNTING TUBE LENGTH
24"	18"	Dual	E11HDXCDM24-6	64"
30"	24"	Dual	E11HDXCDM30-6	70"
36"	30"	Dual	E11HDXCDM36-6	76"
42"	36"	Dual	E11HDXCDM42-6	82"
48"	42"	Dual	E11HDXCDM48-6	88"
54"	48"	Dual	E11HDXCDM54-6	94"
60"	52"	Dual	E11HDXCDM60-6	100"
72"	66"	Dual	E11HDXCDM72-6	112"
84"	78"	Dual	E11HDXCDM84-6	124"

## E11HDX CLEANER

BELT WIDTH MINUS 12" BLADE  
ORDERING INFORMATION E11HDX Series

BELT WIDTH	BLADE WIDTH	S.S. SPRING	ORDER NO.	MOUNTING TUBE LENGTH
30"	18"	Dual	E11HDXCDM30-12	70"
36"	24"	Dual	E11HDXCDM36-12	76"
42"	30"	Dual	E11HDXCDM42-12	82"
48"	36"	Dual	E11HDXCDM48-12	88"
54"	42"	Dual	E11HDXCDM54-12	94"
60"	48"	Dual	E11HDXCDM60-12	100"
72"	60"	Dual	E11HDXCDM72-12	112"
84"	72"	Dual	E11HDXCDM84-12	124"

## E11HDX CLEANER

BELT WIDTH MINUS 18" BLADE  
ORDERING INFORMATION E11HDX Series

BELT WIDTH	BLADE WIDTH	S.S. SPRING	ORDER NO.	MOUNTING TUBE LENGTH
36"	18"	Dual	E11HDXCDM36-18	76"
42"	24"	Dual	E11HDXCDM42-18	82"
48"	30"	Dual	E11HDXCDM48-18	88"
54"	36"	Dual	E11HDXCDM54-18	94"
60"	42"	Dual	E11HDXCDM60-18	100"
72"	54"	Dual	E11HDXCDM72-18	112"
84"	66"	Dual	E11HDXCDM84-18	124"

## BLADE MATERIAL OPTIONS

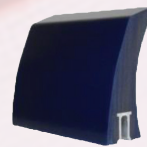

Eagle Ev-R-Wear™  
High Performance  
Blue 85A



Solid Polyurethane  
Orange 90A



Chemical/Acid  
Resistant  
Green 80A



Heat Resistant  
-40 to 300 °F  
Red 95A

