

E12 CANTILEVER Secondary Cleaner

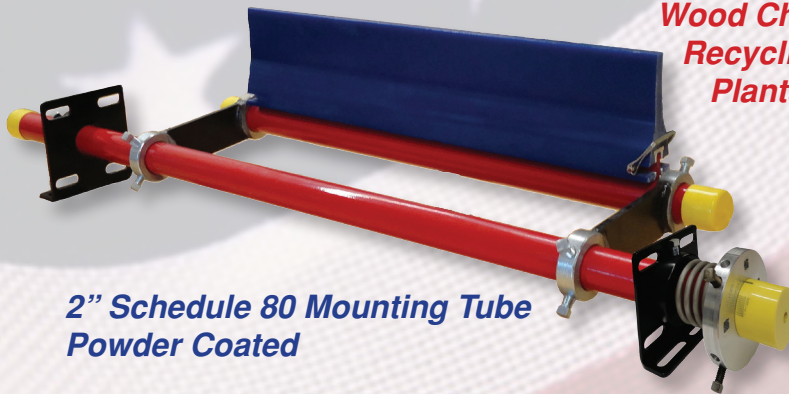

GET THE **EAGLE EDGE!**
MADE IN THE U.S.A.



**2" Schedule 80 Mounting Tube
Powder Coated**

**Cleaners 18-72" Belt Width
Standard Blades Are Full Belt Width -2**

AVAILABLE IN ALL STAINLESS STEEL **BENEFITS**

By designing the tensioner bar behind the blade, vine and stringy carryback are prevented from wrapping up the tensioner. This wrapping up, which interferes in the blade and full belt contact, is resolved. This design also prevents too much tension that causes belt damage and premature blade wear.

UNIVERSAL MOUNTING BRACKET

- † Can be flange mounted or foot mounted
- † Composite molded bushing eliminates corrosion and build-up between bracket and mounting tube. Allow constant blade pressure to belt.
- † Elongated holes allow for easy alignment of installation.
- † Set screw that allows pre-tensioning of cleaner making it more accurate.

**Paper Mill,
Wood Chip &
Recycling
Plants**

Our E12 Cantilever Secondary Cleaner is designed for specific carryback problem areas.

- † Stringy carryback in recycling plants
- † Vine carryback in debarking applications

EZ TORSION SYSTEM LIFETIME WARRANTY

This revolutionary design is the simplest and most accurate tensioning system on the market.

Only 4 components make up the EZ Torsion System.

- † Universal Torsion Mounting Bracket
- † Stainless Steel Spring
- † EZ Torsion Ring
- † Tension Guide Cap

Ev-r-wear™ Blade

Our special formulated urethane with additives has been tested and proven to last longer than any other blade on the market.

WE GUARANTEE IT . . .

- † Premium urethane
 - † Additive for lubricity (non-stick)
 - † Additive for high abrasion
- "With over 35 years molding experience."

AMERICAN EAGLE MANUFACTURING LLC

www.AmericanEagleManufacturing.com

1-866-713-8985

BY FAR THE EASIEST CLEANER TO INSTALL AND MAINTAIN

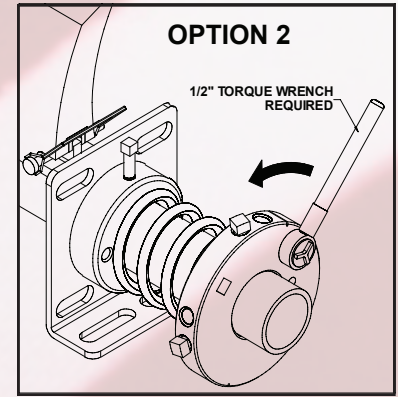
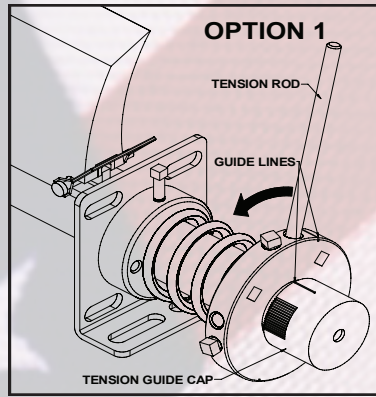
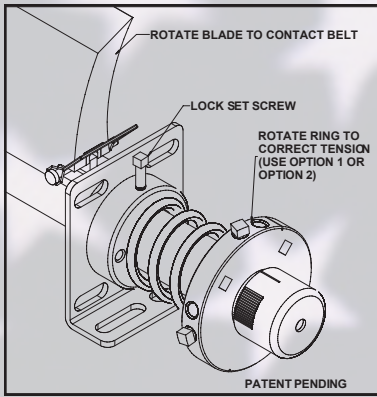

Once the correct tension is set, tighten the 2 set screws on the Easy Torsion Ring then release the set screw on top of the Universal Torsion Mounting Bracket, to transfer the tension to the blade.

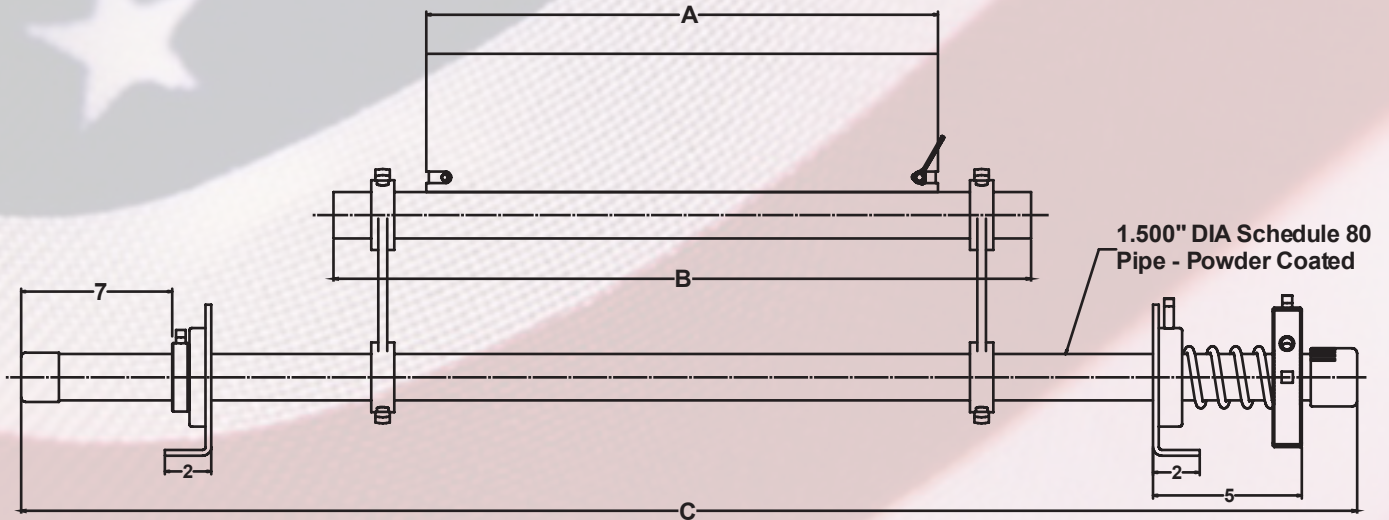

Technical and Ordering Information

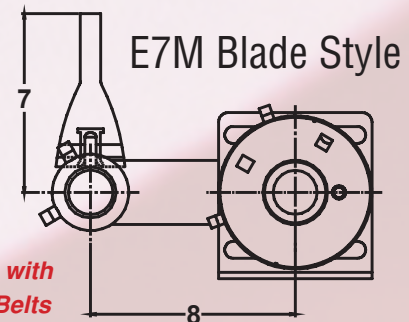
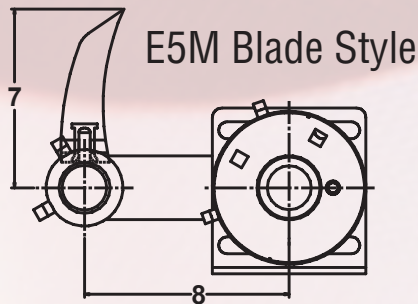

Compatible with
Reversing Belts

E12 Secondary Cleaner with E5M Blade

BELT WIDTH	A	B	C	PART NO.
18	16	24	68	E12SCE5M18
24	22	30	74	E12SCE5M24
30	28	36	80	E12SCE5M30
36	34	42	86	E12SCE5M36
42	40	48	92	E12SCE5M42
48	46	54	98	E12SCE5M48
54	52	60	104	E12SCE5M54
60	58	66	110	E12SCE5M60
72	70	78	122	E12SCE5M72

E12 Secondary Cleaner with E7M Blade

BELT WIDTH	A	B	C	PART NO.
18	16	24	68	E12SCE7M18
24	22	30	74	E12SCE7M24
30	28	36	80	E12SCE7M30
36	34	42	86	E12SCE7M36
42	40	48	92	E12SCE7M42
48	46	54	98	E12SCE7M48
54	52	60	104	E12SCE7M54
60	58	66	110	E12SCE7M60
72	70	78	122	E12SCE7M72