

E5 Eaglet Primary Cleaner



GET THE **EAGLE EDGE!**
MADE IN THE U.S.A.



**Blade
Height
6"**

**2" Schedule 80 Pipe
Powder Coated**

**Cleaners 18-48" Belt Width
Standard Blades -2 & -8 Belt Width**

Ev-r-wear™ Blade

Our special formulated urethane with additives has been tested and proven to last longer than any other blade on the market.

WE GUARANTEE IT . . .

- † Premium urethane
 - † Additive for lubricity (non-stick)
 - † Additive for high abrasion
- "With over 35 years molding experience."

We don't cast this formula because it's easy or cheap, we cast it because it's the BEST."

David K. Liland, President

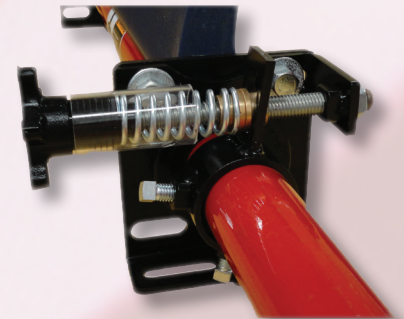

PATENT PENDING

UNIVERSAL MOUNTING BRACKET

- † Can be face mounted or foot mounted
- † Composite molded bushing eliminates corrosion and build-up between bracket and pipe. Allows constant blade pressure to belt.
- † Elongated holes allow for easy alignment of installation.

**BY FAR THE EASIEST CLEANER
TO INSTALL AND MAINTAIN**

EASY-TORQUE SYSTEM

- † Mounted left or right
- † Single or Dual tensioner available
- † Bronze bushings
- † Spring Guard
- † Knob for easy tension adjustment
- † Designed for limited space

EASY TO SET AND STAYS SET

**"Not just assembled in the U.S.A.
but made in the U.S.A."**

AMERICAN EAGLE MANUFACTURING LLC

www.AmericanEagleManufacturing.com

1-866-713-8985

E5 Eaglet Primary Cleaner



GET THE **EAGLE EDGE!**
MADE IN THE U.S.A.

E5 CLEANER

ORDERING INFORMATION E5 Series

BELT WIDTH	EASY-TORQUE	ORDER NUMBER	-2 BLADE WIDTH	LBS	ORDER NUMBER	-8 BLADE WIDTH	LBS
18"	Single	E5CSM18	16"	42	E5CSM18-8	10"	39
24"	Single	E5CSM24	22"	46	E5CSM24-8	16"	43
30"	Single	E5CSM30	28"	52	E5CSM30-8	22"	49
36"	Single	E5CSM36	34"	58	E5CSM36-8	28"	55
42"	Dual	E5CDM42	40"	63	E5CDM42-8	34"	60
48"	Dual	E5CDM48	46"	71	E5CDM48-8	40"	68

Cleaner will come with Tensioner on right side unless specified left. Dual Available upon request.

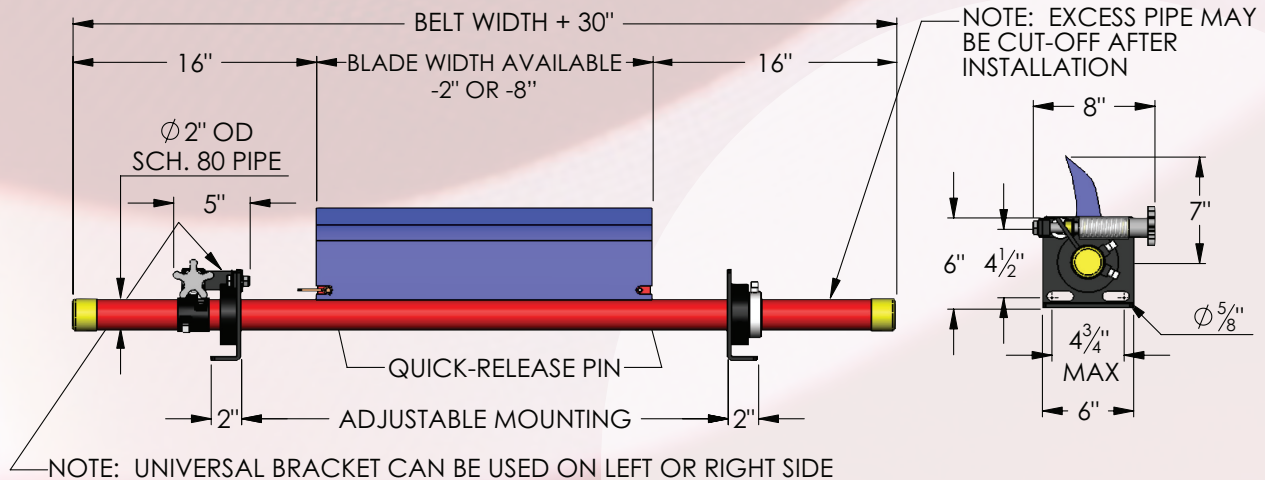

BLADE MATERIAL OPTIONS



FDA
Polyurethane
Natural 85A



Heat Resistant
-40 to 300 °F
Red 95A

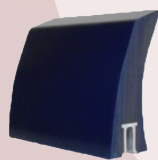

Eagle Ev-R-Wear™
High Performance
Blue 85A



Chemical/Acid
Resistant
Green 80A



Solid
Polyurethane
Orange 90A

AMERICAN EAGLE MANUFACTURING LLC

www.AmericanEagleManufacturing.com

1-866-713-8985