

URETHANE FLANGE DROP GASKETS

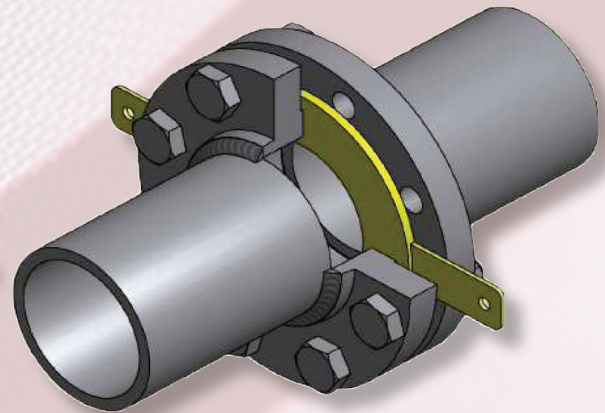

GET THE **EAGLE EDGE!**
MADE IN THE U.S.A.

Designed with your Safety in mind!

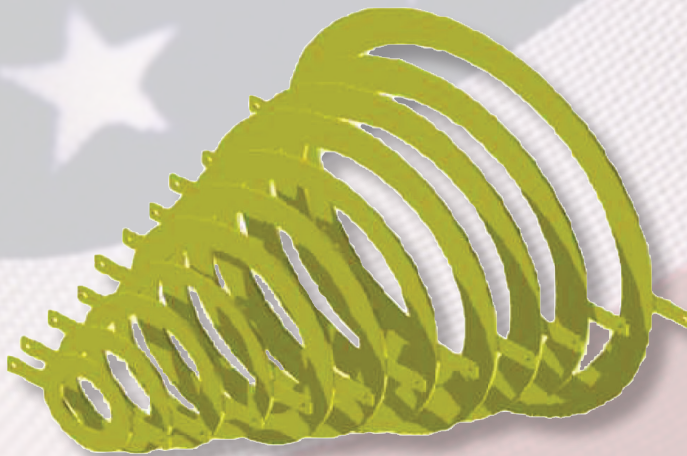

Flange drop gaskets are molded out of durable urethane engineered for compression between two steel flanges. Gaskets are molded 1/4" thickness to help with miss alignment problems. American Eagle drop gaskets are designed for quick and easy installation. AE drop gaskets have a new two point alignment tab on top and bottom making installation more precise at the same time keeping operators fingers safe and out of pinch point areas.

ORDERING INFORMATION

PIPE SIZE	Part Number	THICKNESS	WEIGHT
4	UFDG-4-250	1/4"	0.35 lbs.
6	UFDG-6-250	1/4"	0.45 lbs.
8	UFDG-8-250	1/4"	.55 lbs.
10	UFDG-10-250	1/4"	.75 lbs.
12	UFDG-12-250	1/4"	1.25 lbs.
14	UFDG-14-250	1/4"	1.35 lbs.
16	UFDG-16-250	1/4"	1.5 lbs.
18	UFDG-18-250	1/4"	2.00 lbs.
19	UFDG-19-250	1/4"	2.10 lbs.
20	UFDG-20-250	1/4"	2.25 lbs.
24	UFDG-24-250	1/4"	2.5 lbs.

mold to size +/-1/8 on o.d. and i.d., -0/+0.040 on Thickness

American Eagle Manufacturing can also mold custom sizes and hole patterns. Just fill out our custom work sheet.

AMERICAN EAGLE MANUFACTURING LLC

www.AmericanEagleManufacturing.com

1-866-713-8985

Gasket WorkSheet

Name: _____
 Company: _____
 Email: _____
 Phone: (optional) _____
 City: _____
 State: _____
 Zip Code: _____
 Customer Type:
 Distributor
 OEM Manufacturer
 End User

	Description	Dimension
"A"	Outside Diameter	*
"B"	Bolt Circle Diameter	
"C"	Inside Diameter	*
"D"	Hole Diameter	
	Number Of Holes	
"T"	Thickness	*
"M"	Material	
"Q"	Quantity	*

* Required Items For Quotation.

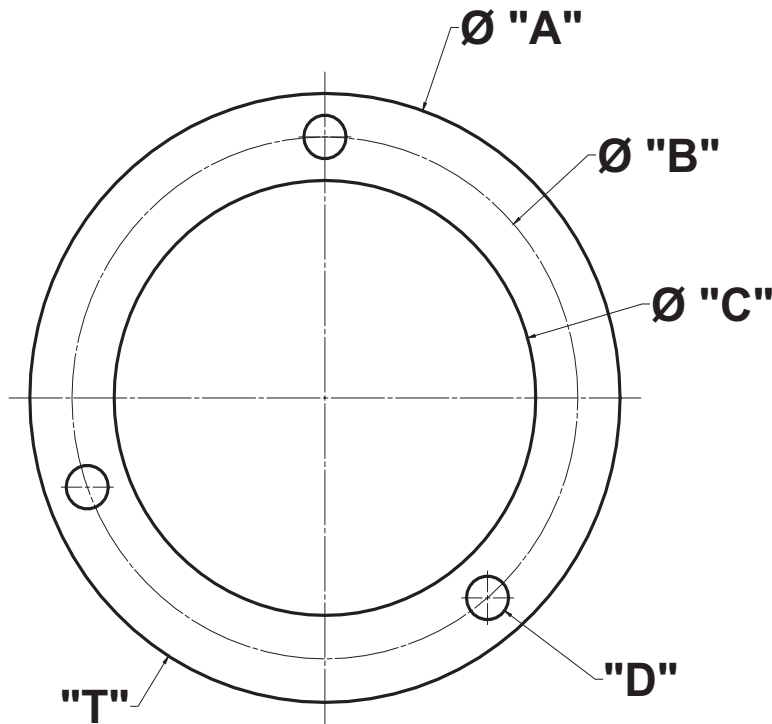

-	-	-	-
-	-	-	-
-	-	-	-
-	-	-	-
REV.	DESCRIPTION	BY DATE	CHK'D DATE

St'd Tolerances for Cast Urethane

(Unless otherwise noted)
 Decimal Dimensions:
 3 Decimal places ±.015
 2 Decimal places ±.030
 Hole locations ±.030
 Angular Dimensions:
 In degrees ±60 min.
 In degrees & min. ±15 min.
 Fractional Dimensions ±1/32

Design derived from customer supplied drawings and or parts

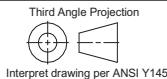

This drawing in design and detail is the property of American Eagle Manufacturing, LLC. It is returnable upon request and must not be reproduced or the information contained transmitted to any unauthorized person or organization without written consent from American Eagle Manufacturing, LLC. It is to be used only in connection with our work as authorized by us. All rights of design and invention are reserved.

American Eagle Manufacturing, LLC

201 Kale Road
 New Bern, NC 28562
 Ph: 256-413-8985 Fax: 256-413-8986
 Email: eaglecleaners@aol.com

Drawn
H.D.Boggs 21 Nov. 2010
 ENGINEER

SIZE
A EG - _____
 DWG NUMBER

SCALE: N.T.S.

REV - 000 SHEET 1 OF 1