

GAP DIMENSION CHART	
Pulley Diameter	"G" Dimension
18	4 1/4
20	3 5/8
24	3 5/8
30	3 1/2
36-42	3 1/8
48	3
Tolerance no more than $\pm 1/4$ "	

*Multiply "A" x 2 for pulley diameter.

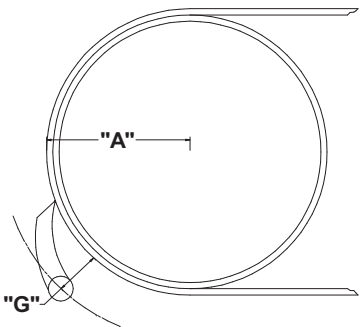

-2" Blade Width				-8" Blade Width			
Part No.	Belt Width "A"	Blade Width "B"	Pipe Width "C"	Part No.	Belt Width "A"	Blade Width "B"	Pipe Width "C"
E4HDSCM18	18"	16"	56"	E4HDSCM18-8	18"	10"	56"
E4HDSCM24	24"	22"	62"	E4HDSCM24-8	24"	16"	62"
E4HDSCM30	30"	28"	68"	E4HDSCM30-8	30"	22"	68"
E4HDSCM36	36"	34"	74"	E4HDSCM36-8	36"	28"	74"
E4HDSCM42	42"	40"	80"	E4HDSCM42-8	42"	34"	80"
E4HDSCM48	48"	46"	86"	E4HDSCM48-8	48"	40"	86"
E4HDSCM54	54"	52"	92"	E4HDSCM54-8	54"	46"	92"
E4HDSCM60	60"	58"	98"	E4HDSCM60-8	60"	52"	98"
E4HDSCM72	72"	70"	110"	E4HDSCM72-8	72"	64"	110"

Cleaner will come with Tensioner on right side unless specified left.
 *Cleaner also available in all Stainless Steel

PATENT PENDING

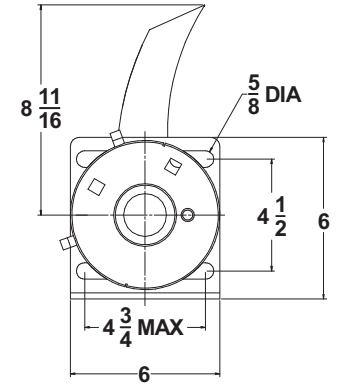
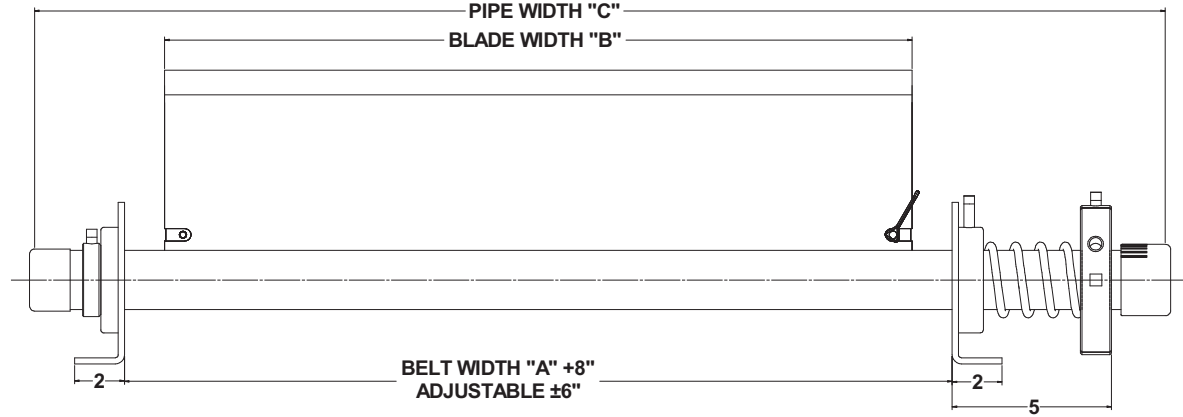
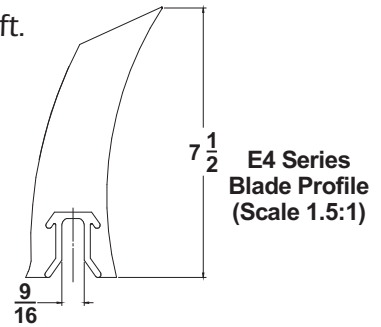

-	-	-	-
-	-	-	-
001	Redesigned E4HP Cleaner to show new EasyTorsion Ring	JSL	-
REV.	DESCRIPTION	12-27-11	-
		BY	CHK'D
		DATE	DATE

St'd Tolerances for Cast Urethane
 (Unless otherwise noted)
 Decimal Dimensions:
 3 Decimal places ± 0.015
 2 Decimal places ± 0.030
 Hole locations ± 0.030
 Angular Dimensions:
 In degrees ± 60 min.
 In degrees & min. ± 15 min.
 Fractional Dimensions $\pm 1/32$

St'd Tolerances for Machined Urethane
 (Unless otherwise noted)
 Decimal Dimensions:
 3 Decimal places ± 0.005
 2 Decimal places ± 0.015
 Hole locations ± 0.010
 Angular Dimensions:
 In degrees ± 30 min.
 In degrees & min. ± 5 min.
 Fractional Dimensions $\pm 1/64$

Design derived from customer supplied drawings and or parts

Third Angle Projection
 Interpret drawing per ANSI Y145

This drawing in design and detail is the property of American Eagle Manufacturing, LLC. It is returnable upon request and must not be reproduced or the information contained transmitted to any unauthorized person or organization without written consent from American Eagle Manufacturing, LLC. It is to be used only in connection with our work as authorized by us. All rights of design and invention are reserved.

Drawn **Jeff Langley** 12-16-11
 APPROVED BY **David Liland** 12-16-11
 SCALE: N.T.S.

201 Kale Road
 New Bern, NC 28562
 Ph: 252-633-0603 Fax: 252-633-5487
 www.AmericanEagleManufacturing.com

E4 Heavy Duty Primary Cleaner
 SIZE **A**
 REV - 001 SHEET 1 OF 1