

GAP DIMENSION CHART	
Pulley Diameter	"G" Dimension
14	3 3/4
16	3 3/4
18	3 1/2
20	3 1/2
24	3 1/4
30	3
36-42	2 3/4
Tolerance no more than $\pm 1/4$ "	

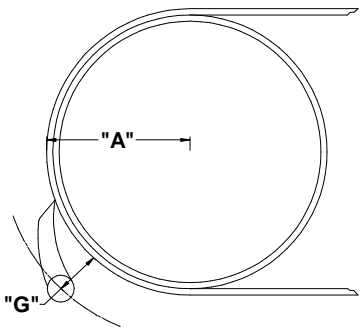

*Multiply "A" x 2 for pulley diameter.

Cleaner Specifications								
-2" Blade Width				-8" Blade Width				
Part No.	Belt Width "A"	Blade Width "B"	Pipe Width "C"	Part No.	Belt Width "A"	Blade Width "B"	Pipe Width "C"	
E5CSM18	18"	16"	48"	E5CSM18-8	18"	10"	48"	
E5CSM24	24"	22"	54"	E5CSM24-8	24"	16"	54"	
E5CSM30	30"	28"	60"	E5CSM30-8	30"	22"	60"	
E5CSM36	36"	34"	66"	E5CSM36-8	36"	28"	66"	
E5CDM42	42"	40"	72"	E5CDM42-8	42"	34"	72"	
E5CDM48	48"	46"	78"	E5CDM48-8	48"	40"	78"	

18"-36" - Single Tensioner
 42"-48" - Dual Tensioner
 Single Tensioner Cleaner will come with Tensioner on right side unless specified left.

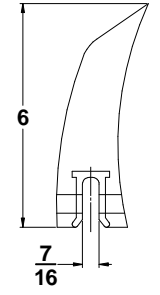

E5 Series
Blade Profile
(Scale 1.5:1)

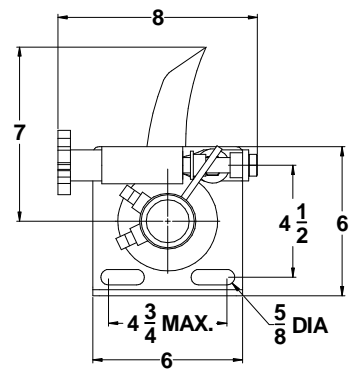
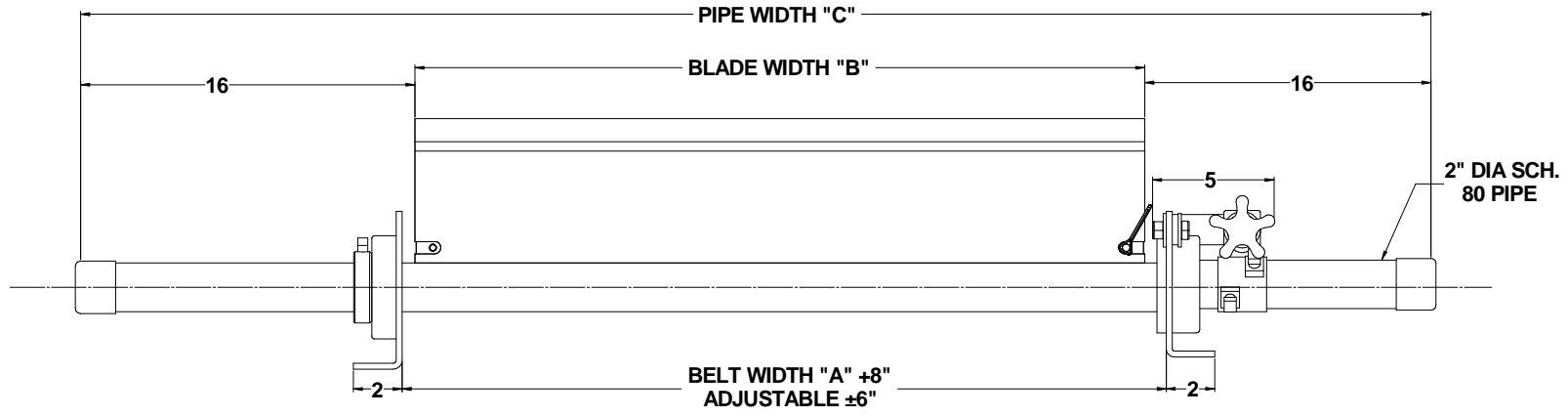

REV.	DESCRIPTION	BY	CHK'D
		DATE	DATE
-	-	-	-
-	-	-	-
-	-	-	-
-	-	-	-

St'd Tolerances for Cast Urethane
 (Unless otherwise noted)
 Decimal Dimensions:
 3 Decimal places ± 0.015
 2 Decimal places ± 0.030
 Hole locations ± 0.030
 Angular Dimensions:
 In degrees ± 60 min.
 In degrees & min. ± 15 min.
 Fractional Dimensions $\pm 1/32$

St'd Tolerances for Machined Urethane
 (Unless otherwise noted)
 Decimal Dimensions:
 3 Decimal places ± 0.005
 2 Decimal places ± 0.015
 Hole locations ± 0.010
 Angular Dimensions:
 In degrees ± 30 min.
 In degrees & min. ± 5 min.
 Fractional Dimensions $\pm 1/64$

Design derived from customer supplied drawings and or parts

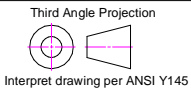

This drawing in design and detail is the property of American Eagle Manufacturing, LLC. It is returnable upon request and must not be reproduced or the information contained transmitted to any unauthorized person or organization without written consent from American Eagle Manufacturing, LLC. It is to be used only in connection with our work as authorized by us. All rights of design and invention are reserved.



201 Kale Road
 New Bern, NC 28562
 Ph: 252-633-0603 Fax: 252-633-5487
 www.AmericanEagleManufacturing.com

Drawn **Jeff Langley** 12-15-11
 APPROVED BY **David Liland** 12-15-11
 SCALE: N.T.S.

SIZE
A

**E5 Eaglet
 Primary Cleaner**
 REV - 000 SHEET 1 OF 1