

GAP DIMENSION CHART	
Pulley Diameter	"G" Dimension
14	3 3/4
16	3 3/4
18	3 1/2
20	3 1/2
24	3 1/4
30	3
36-42	2 3/4
Tolerance no more than $\pm 1/4$ "	

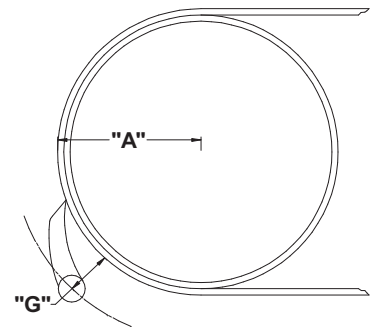

*Multiply "A" x 2 for pulley diameter.

Cleaner Specifications								
-2" Blade Width				-8" Blade Width				
Part No.	Belt Width "A"	Blade Width "B"	Pipe Width "C"	Part No.	Belt Width "A"	Blade Width "B"	Pipe Width "C"	
E5HPCSM18	18"	16"	48"	E5HPCSM18-8	18"	10"	48"	
E5HPCSM24	24"	22"	54"	E5HPCSM24-8	24"	16"	54"	
E5HPCSM30	30"	28"	60"	E5HPCSM30-8	30"	22"	60"	
E5HPCSM36	36"	34"	66"	E5HPCSM36-8	36"	28"	66"	
E5HPCSM42	42"	40"	72"	E5HPCSM42-8	42"	34"	72"	
E5HPCSM48	48"	46"	78"	E5HPCSM48-8	48"	40"	78"	

Cleaner will come with Tensioner on right side unless specified left.
 *E5HP Eaglet Cleaner also available in all Stainless Steel

PATENT PENDING

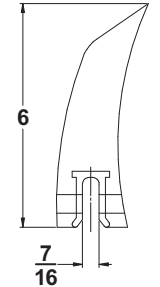

**E5 Series
Blade Profile
(Scale 1.5:1)**

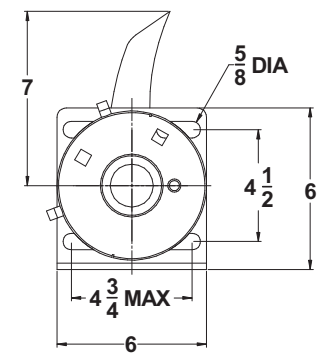
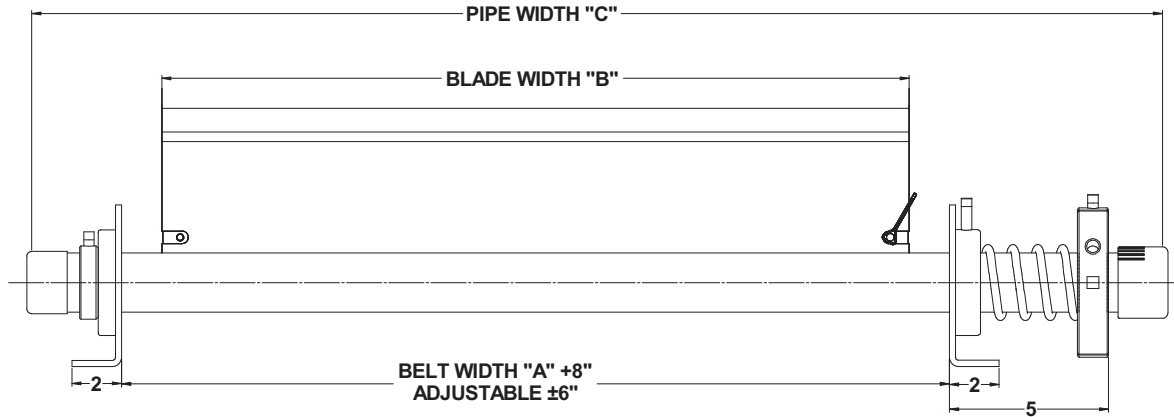

REV.	DESCRIPTION	BY	CHK'D
001	Redesigned E5HP Eaglet Cleaner to show new EasyTorsion Ring	JSL	-
		12-27-11	-
		DATE	DATE

St'd Tolerances for Cast Urethane
 (Unless otherwise noted)
 Decimal Dimensions:
 3 Decimal places ± 0.015
 2 Decimal places ± 0.030
 Hole locations ± 0.030
 Angular Dimensions:
 In degrees ± 60 min.
 In degrees & min. ± 15 min.
 Fractional Dimensions $\pm 1/32$

St'd Tolerances for Machined Urethane
 (Unless otherwise noted)
 Decimal Dimensions:
 3 Decimal places ± 0.005
 2 Decimal places ± 0.015
 Hole locations ± 0.010
 Angular Dimensions:
 In degrees ± 30 min.
 In degrees & min. ± 5 min.
 Fractional Dimensions $\pm 1/64$

Design derived from customer supplied drawings and or parts

Third Angle Projection
 Interpret drawing per ANSI Y145

This drawing in design and detail is the property of American Eagle Manufacturing, LLC. It is returnable upon request and must not be reproduced or the information contained transmitted to any unauthorized person or organization without written consent from American Eagle Manufacturing, LLC. It is to be used only in connection with our work as authorized by us. All rights of design and invention are reserved.

Drawn **Jeff Langley** 12-15-11
 APPROVED BY **David Liland** 12-15-11
 SCALE: N.T.S.

201 Kale Road
 New Bern, NC 28562
 Ph: 252-633-0603 Fax: 252-633-5487
 www.AmericanEagleManufacturing.com

**E5HP Eaglet
Primary Cleaner**

SIZE **A**

REV - 001 SHEET 1 OF 1